

Floor PRF.168

User & Installation Manual

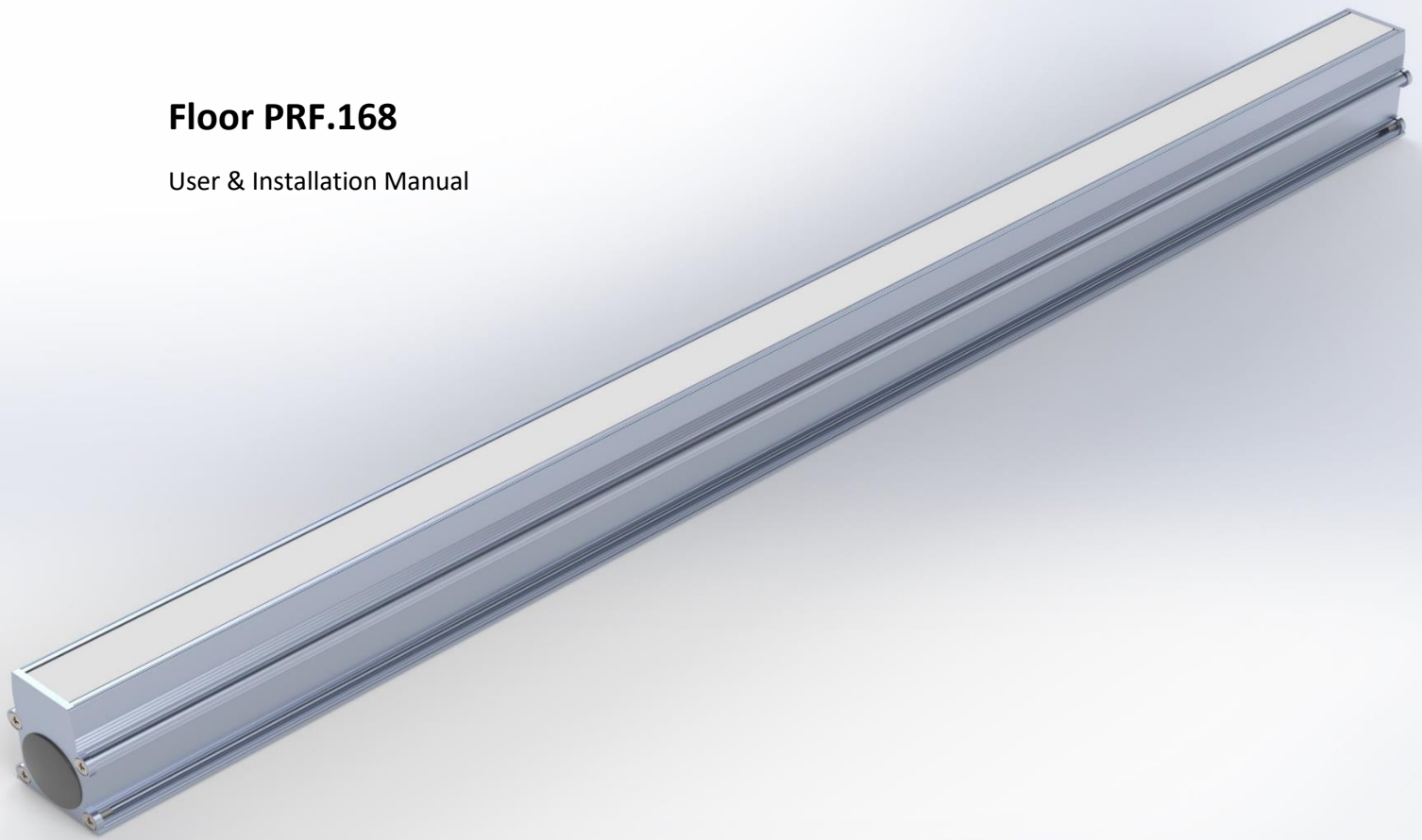

General notes and precautions.

Before first use.

- Make sure to read thoroughly all the instructions before using the BASELINE.
- In case that you do not understand any of the instructions or have any doubt for the installation or operation of the BASELINE, please consult your supplier.
- A specialized technician must do the installation of BASELINE.

Installation.

- BASELINE must not be installed, in any case, on flammable areas.
- Do not install BASELINE near any kind of heating source.
- Make sure that the power supply is turned off during the installation procedure.



Mechanical.

- Make sure that BASELINE is properly installed, safely mounted, and connected.

Electrical.

- The luminaire must be connected only by a qualified electrician.
- The supply input of multichannel BASELINE models (RGBW, Tunable white) is common anode, and the appropriate power supply and controller should be used.
- Disconnect the power supply for any service.

General.

- Baseline is not suitable for drive or walk over applications.
- Do not try to fix any damage or malfunction, by opening the Baseline.
- BASELINE should be cleaned only with a soft cloth and water.
- The manufacturer is not responsible for any injury or damage that will occur from the improper installation or use of the product.
- The safety of this fixture is guaranteed only if you comply with the following instructions.
- Make sure that all the local laws and regulations are followed during the installation procedure.
- Remember to conserve these instructions in a safe place.
- At the end of its lifetime BASELINE must be delivered in a special waste collection center. The improper disposal can cause damages for the environment and poses dangers for the human health.

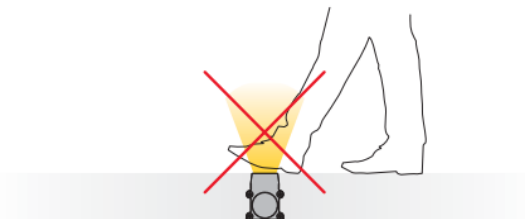

Installation.

Before starting the installation, please read the section “General notes and precautions.”

Mount the installation box in the desired area, the area has to be level and uniform.

ATTENTION: Make sure that there is an appropriate drainage system, to avoid accumulation of standing water.

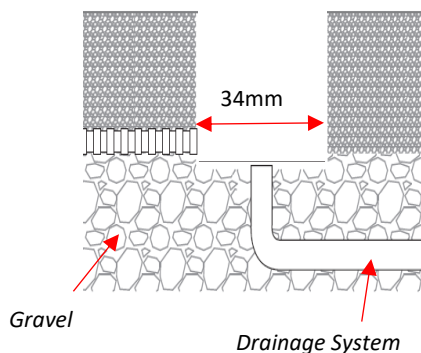
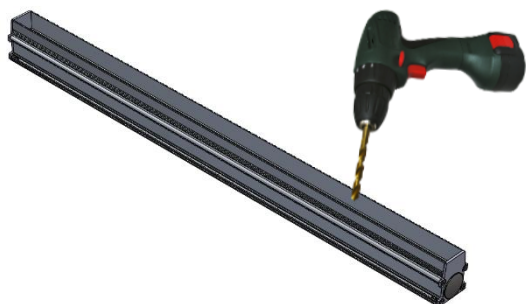

In order to mount more than one PRF.168 mounting boxes in-line, the end caps must be removed (a) and PRH.108 alignment kit (b) should be used.

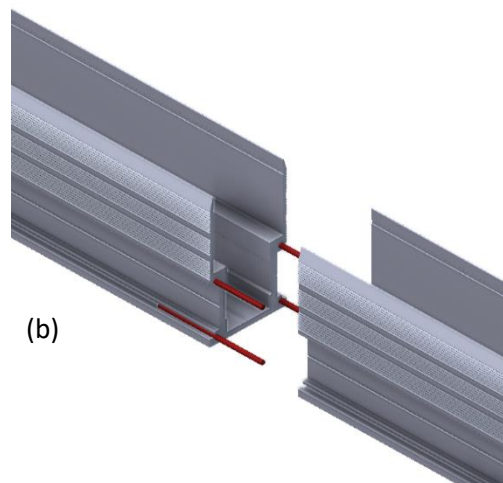
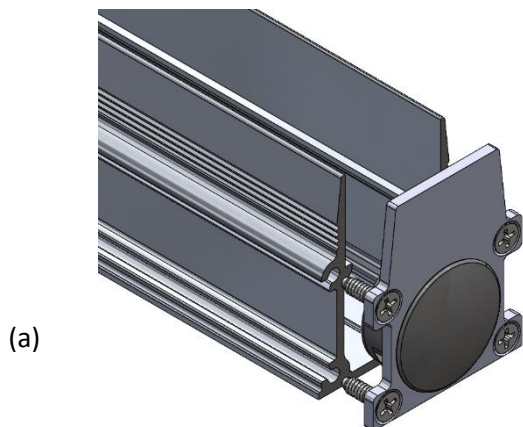

For the proper installation of the mounting boxes the installer must leave the appropriate gap between each mounting box:

- PRF.168 25cm-75cm:0.5mm
- PRF.168 100cm-150cm: 1.00mm
- PRF.168 175cm-200cm: 1.25mm

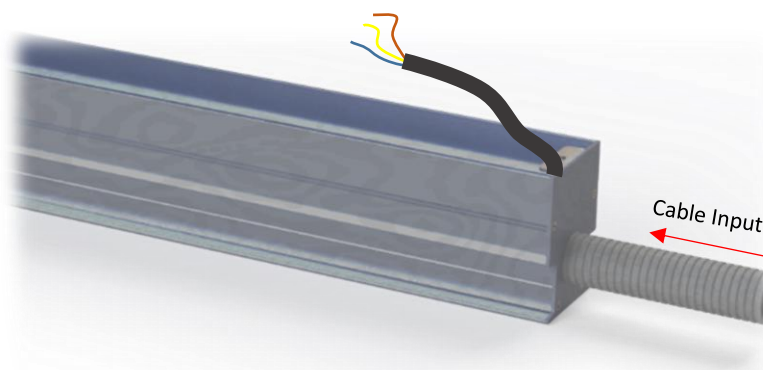
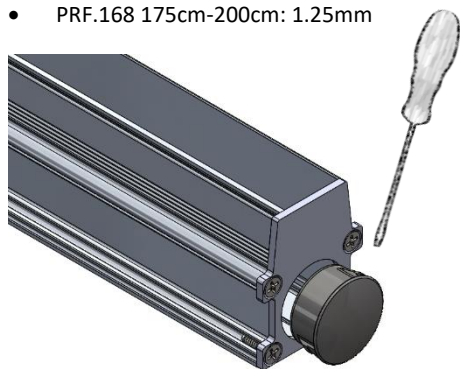

Remove the protecting plug and install an electrical tube in the pre-arranged position.

Pass all the cables through the electrical tubes prior to the concrete pouring.

Installation.

The installer must make sure that the concrete will not enter the mounting box or other components. The usage of painter tape to fill any gaps is recommended. With the mounting box firmly secured and all the electrical tubes and cables arranged then the aluminum profile **PRF.421** can be temporary installed, and the cement can be poured, once the cement is set then the aluminum must be removed.

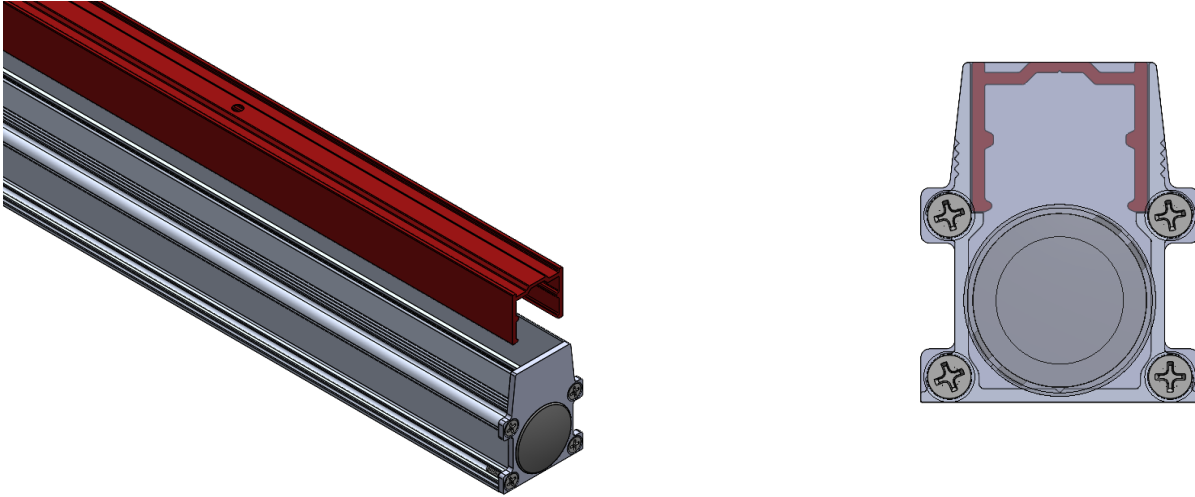

If necessary, the PRF.421 with the Baseline can be secured in place, bolting it on the prearranged location.

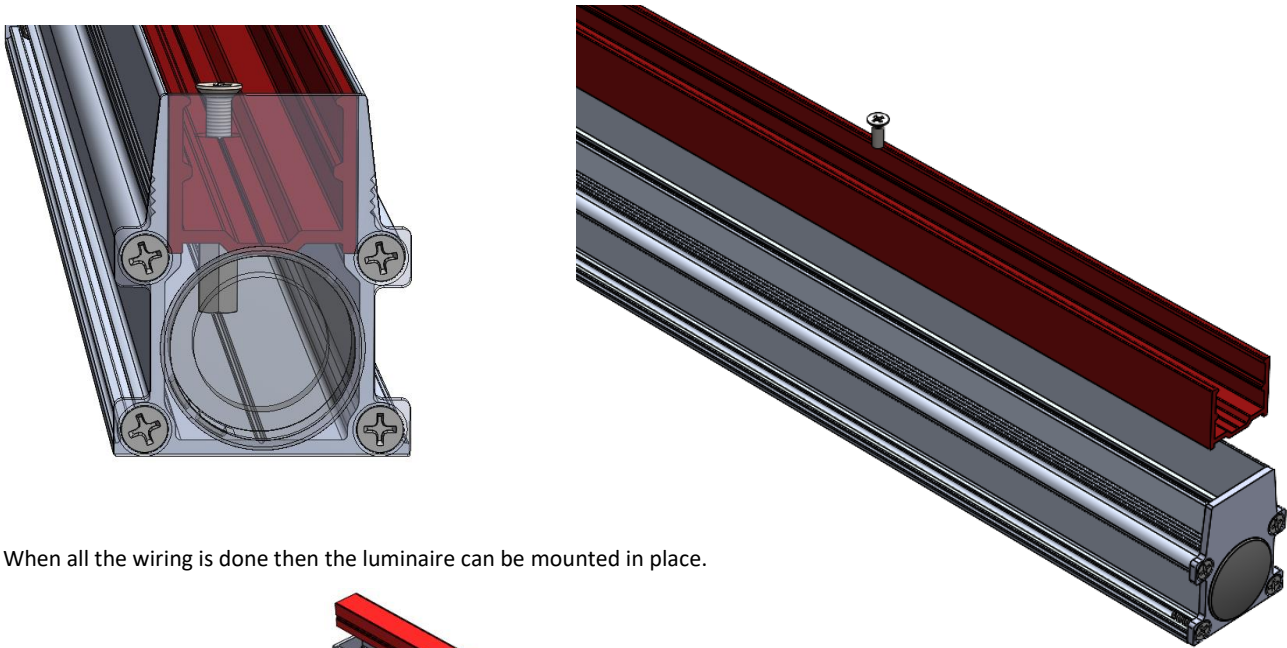

When all the wiring is done then the luminaire can be mounted in place.

